

For Earth, For Life
Kubota

Kubota FRP Johkasou, Wastewater Treatment Plant

The Pinnacle of Water Treatment Technology



H2O
Falcons

UAE +971 50 926 9993
Somaliland +252 63333 9936

✉ info@h2ofalcons.com

🌐 <https://www.h2ofalcons.com/>

Plant Package

Kubota's advanced water treatment technology now delivered in a package

To meet water treatment requirements, we, Kubota commit to offer the most optimal water treatment solutions by utilizing all our technologies and know how. That is our mission as one of Kubota, a leading player in the global and Japan water treatment markets. Kubota now unveils a package incorporating its advanced water treatment engineering expertise, which has been refined through many years of experience in building water treatment plants. Optimal water treatment solutions are available in locations and in sizes customers require. Kubota's "plant package" is sure to serve as the key concept of combined wastewater treatment tanks. Customers who are dedicated to building environmentally friendly communities and lifestyles befitting the 21st century choose Kubota tanks.

Environmental Technology



Water Treatment and Hydraulics

Craftsmanship

Kubota FRP Johkasou, Wastewater Treatment Plant

Small-size Johkasou

This wastewater treatment tank is designed for individual homes and vacation homes to small-scale stores and apartment buildings. It is a standard product.

KZ		HCZ	
Flow rate	Effluent water quality	Flow rate	Effluent water quality
1.0 ~ 2.0(m ³ /day)	BOD 20mg/L T-N 20mg/L	4.2 ~ 10.0(m ³ /day)	BOD 20mg/L T-N 20mg/L
			
Moving bed contact aeration circulation method		Sedimentation-separation anaerobic filter moving bed process	

Large-size Johkasou

This wastewater treatment tank can be adapted to various uses, including large-scale plants, public facilities and apartment buildings. It is custom-made according to the facility's demands.

Membrane Bioreactor Type

Kubota's wastewater treatment tanks are used to preserve the environment in areas where sewage systems are rarely installed. Specifically, this is Kubota's proprietary membrane bioreactor system, where a highly-concentrated activated sludge system is coupled with submerged fine-pore membranes to perform advanced water treatment. Treated water can be reused, without post-treatment, as flush water for toilet and spray water.

KM-SG-NP



Flow rate
5.1 ~ (m³/day)

Effluent water quality
BOD 5mg/L, COD 10mg/L, T-N 10mg/L, T-P 1mg/L



Moving Bed Media Filter Type

This type of wastewater treatment tank constitutes a compact water treatment system. Since this type of tank adopts a moving bed media filter system and incorporates a flow volume control function, it is able to perform stable water treatment for condominiums, stores, plants, and other large-scale buildings.

K-HC-T		K-HC-R	
Flow rate	Effluent water quality	Flow rate	Effluent water quality
10.0 ~ 30.0(m ³ /day)	BOD 20mg/L	20.0 ~ (m ³ /day)	BOD 20mg/L
			
Peak-cut flow solid-liquid separation anaerobic filter moving bed media filter process		Flow equalization-type moving bed media filter process	

Kubota's Refined Expertise Catapults Clean Technology to the Next Stage

Submerged Membrane

Submerged Membrane is patented technology that has been achieved through the combination of Kubota advanced water treatment technology and its unique membrane technology.

The pinnacle of water treatment technology, demonstrating highly advanced and stable water treatment performance

Membrane Bioreactor System

Applicable Products

Model KM-SG-NP

Removal of T-N, T-P

Since it processes high-concentration activated sludge, it is easily possible to remove not only organic pollution such as BOD, but also Nitrogen. Phosphorus can be removed through direct coagulant dosing into the nitrification tank.

Compact installation space

Since it processes high-concentration activated sludge, no sedimentation tank or sludge thickening tank is required. Installation space can be designed 30 ~ 60% smaller compared with conventional systems.

Reusable treated water

Since treated water is discharged through small membrane pores (0.2 μm), treated water is stable and with high quality effluent. Most microorganisms cannot pass through the membrane, so treated water can be reused without the high-treatment facilities.

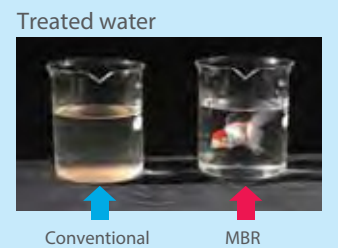

KUBOTA Submerged Membrane Unit®

The KUBOTA Submerged Membrane Unit® incorporates microporous membranes made from polyolefin. Although fluids smaller than the membrane's micropores can permeate the membrane, contaminated ingredients cannot permeate it due to their larger size. Furthermore, contaminants are pulled to the membrane surface. Water flow created by aeration, and air bubbles contact the membrane's surface and move upward while vibrating the surface. This keeps the membrane surface always clean and prevents the micropores from clogging.

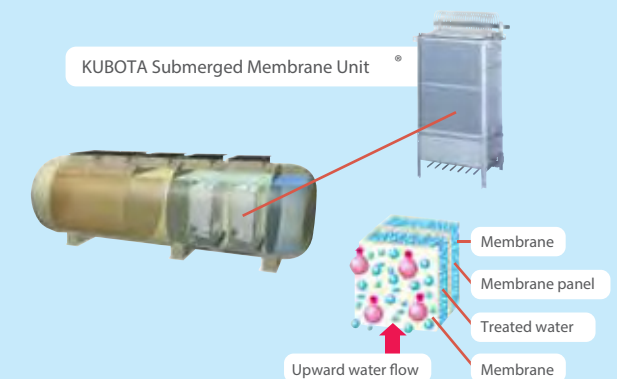

Reducing tank size and stabilizing water treatment at the same time means lower construction costs

Reduction of size

Achieving highly reduction of size by using sponge media and optimisation of design.

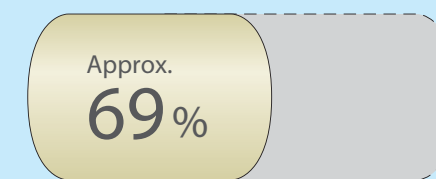

Example of size reduction

Media flow filter method

Achieving highly efficient treatment with moving bed media

The moving bed tank employs a sponge media that is highly capable of retaining microorganisms.

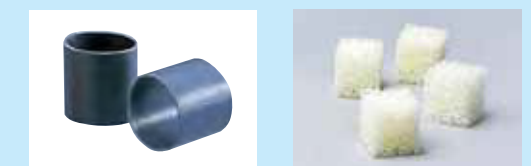

Filter media
Smooth-surfaced cylinder
(φ14-16 × 15 mm)

Sponge media
(20 × 20 × 20 mm)

Moving bed contact aeration circulation method

KZ

Flow rate (m³/day)
1.0 ~ 2.0 N removal

- One more step in space-saving installation
The tank in itself is the smallest design in the world. It can be built without having to choose a place, and even with a small excavation space, it will be labour-saving and make construction quicker.
- All-in-one air-piping unit blower without timer

■ Cross-section perspective

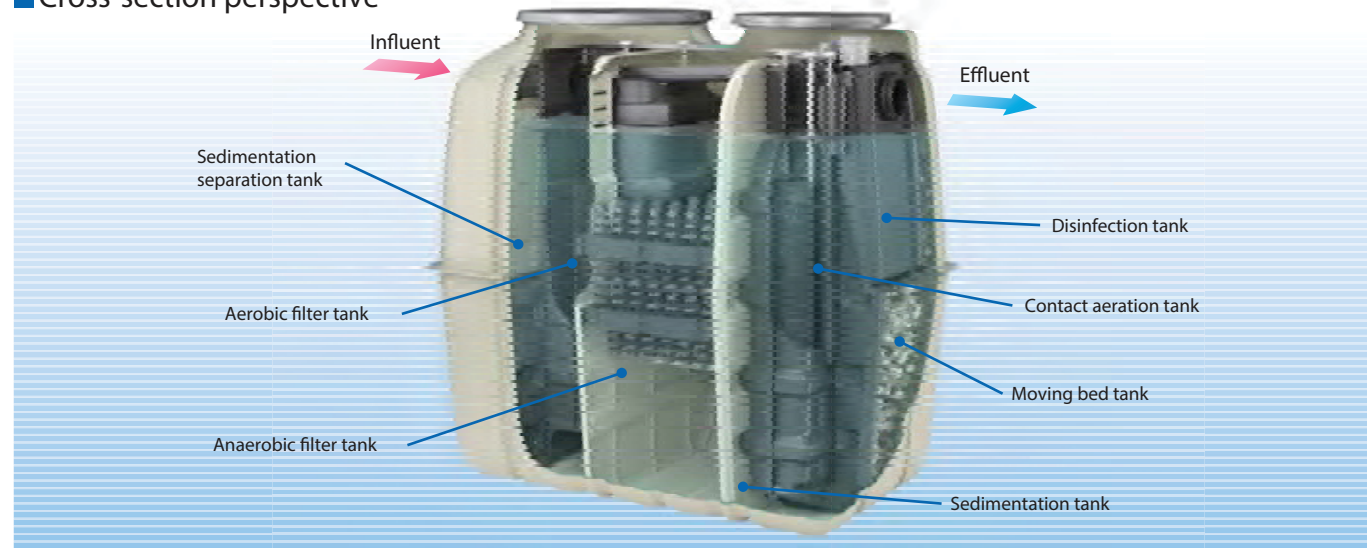

■ Flow sheet

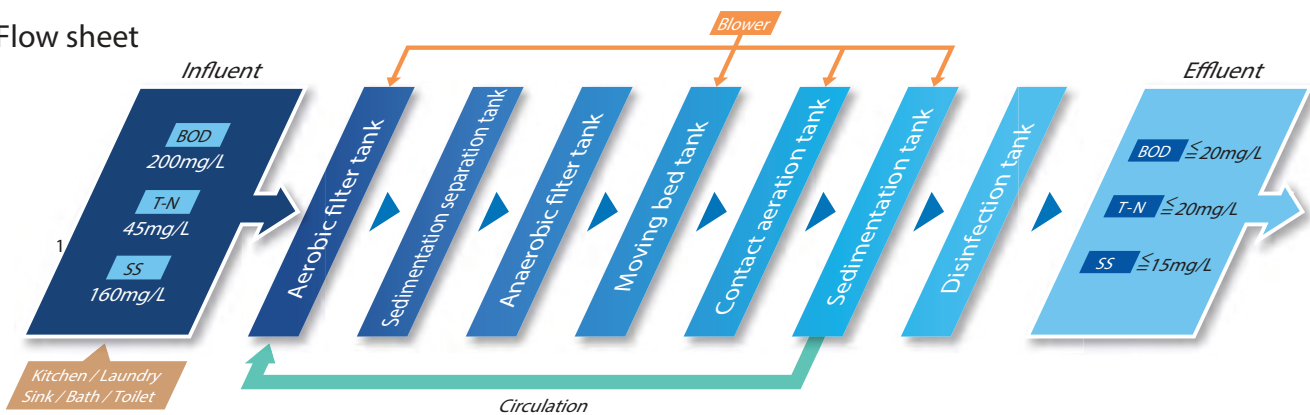

■ Specifications (inf. BOD 200 mg/L)

Model	KZ -5	KZ -7	KZ -10	
Flow rate(m ³ /day)	1.0	1.4	2.0	
Dimensions (mm)	Length A	1,580	2,120	2,790
	Width B	980	980	1,200
	Height C	1,560	1,560	1,580
Manhole number	φ 450	1	3	2
	φ 600	1	-	1
Inf. eff. pipe dia. (mm)		φ 100		
Air pipe dia. (mm)		φ 13		
Capacity (m ³)	Aerobic filter tank	0.105	0.146	0.208
	Sedimentation separation tank	0.432	0.605	0.850
	Anaerobic filter tank	0.528	0.738	1.053
	Moving bed tank	0.205	0.285	0.428
	Contact aeration tank	0.040	0.056	0.081
	Sedimentation tank	0.083	0.112	0.579
	Disinfection tank	0.015	0.015	0.023
	Total capacity	1.408	1.957	3.222
Blower air flow rate (L/min)		60	80	120

■ Drawing example (mm)

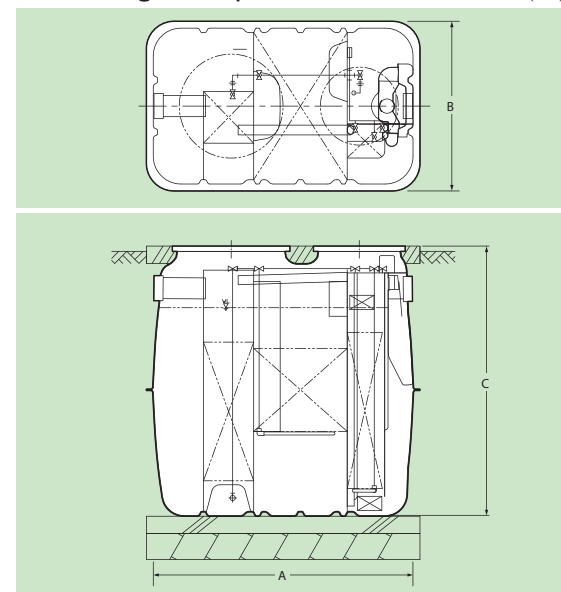

Sedimentation-separation anaerobic filter moving bed process

HCZ

Flow rate (m³/day)
4.2 ~ 10.0 N removal

- Excavation and construction cost are reduce due to the compact design of FRP tank.
- It is easy to install the connection pipe from blower to FRP tank due to one line.
- It is easy to maintain due to the simple system & simple structure inside FRP tank.

■ Cross-section perspective

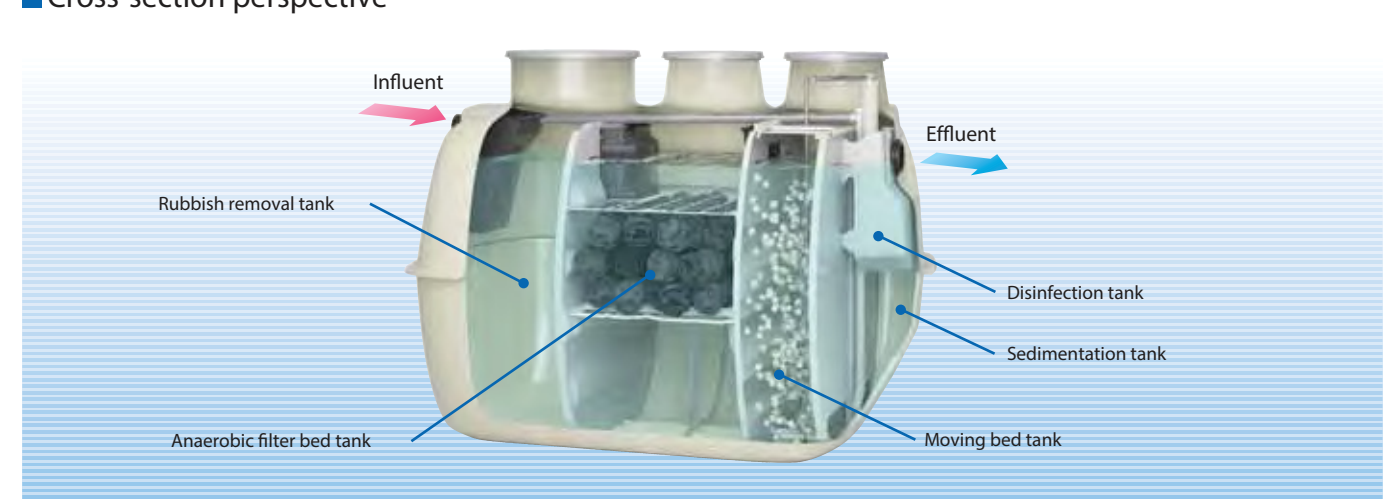

■ Flow sheet

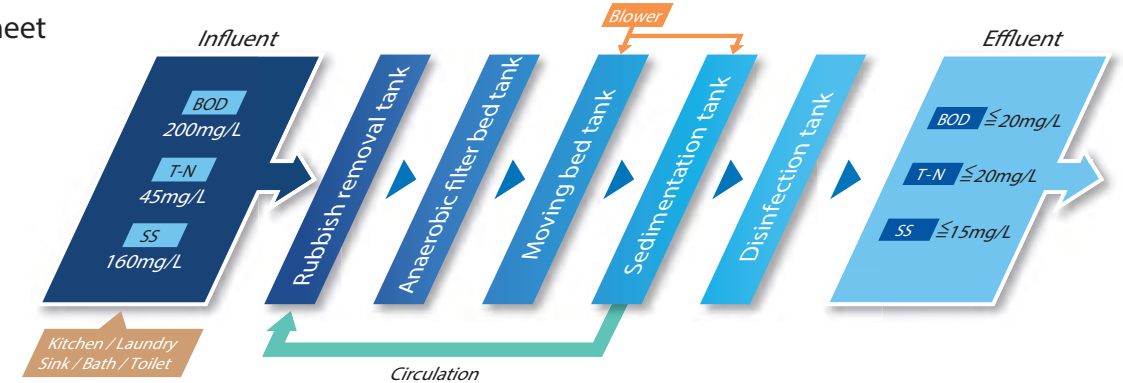

■ Specifications (inf. BOD 200 mg/L)

Model	HCZ-21	HCZ-30	HCZ-40	HCZ-50	
Flow rate(m ³ /day)	4.2	6.0	8.0	10.0	
Dimensions (mm)	Length A	3,255	3,685	4,780	5,760
	Width B	1,870	2,000	2,000	2,000
	Height C	1,950	2,180	2,180	2,180
Manhole number	φ 450	4	1	2	2
	φ 600	-	2	2	2
Inf. eff. pipe dia. (mm)		φ 100			
Air pipe dia. (mm)		φ 20			
Capacity (m ³)	Removal for trash tank	2.366	3.395	4.503	5.626
	Anaerobic filter bed tank	2.372	3.380	4.509	5.626
	Moving bed tank	1.082	1.542	2.054	2.570
	Sedimentation tank	0.481	0.737	1.046	1.046
	Disinfection tank	0.044	0.078	0.105	0.105
	Total capacity	6.345	9.132	12.217	14.973
Blower air flow rate (L/min)		150	200	300	350

■ Drawing example (mm)

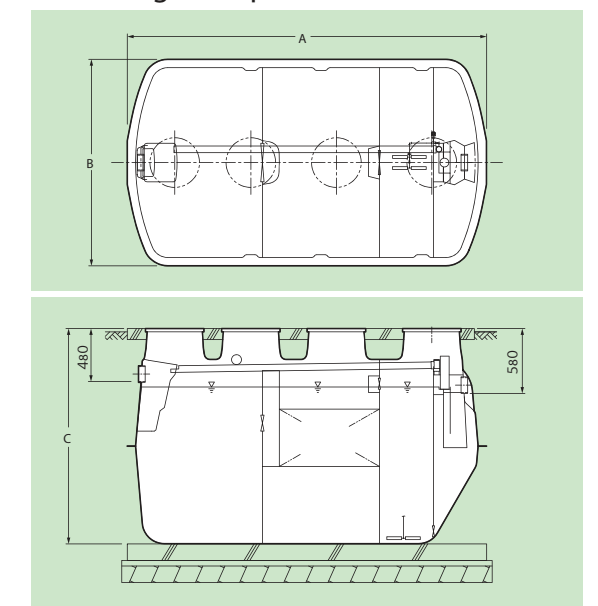

Peak-cut flow solid-liquid separation anaerobic filter moving bed media filter process

K-HC-T

Flow rate (m³/day)
10.0 ~ 30.0

- Capable of handling up to 148 persons (29.6 m³/day) with one tank
- The capacity of the solid-liquid separation tank can be increased as a customization measure against high BOD load wastewater.

■ Cross-section perspective

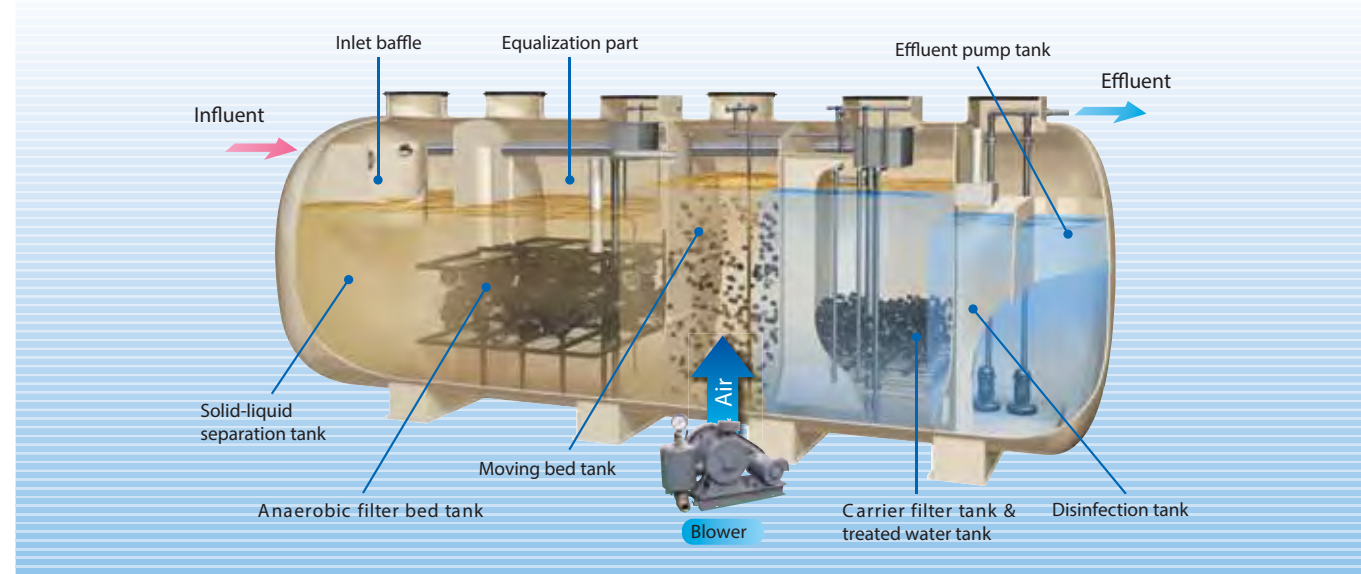

■ Flow sheet

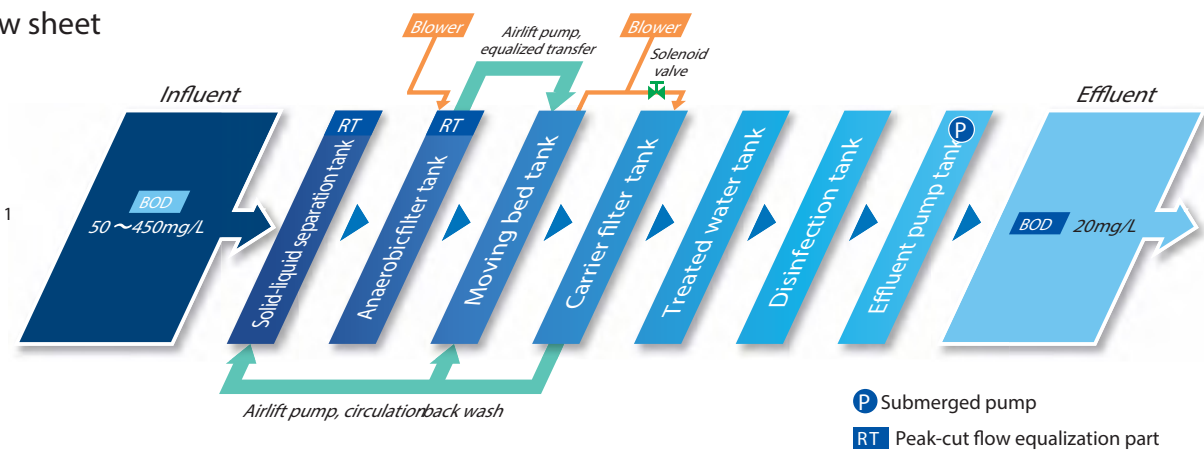

■ Specifications (inf. BOD 200 mg/L, influent 12 hrs/day)

Flow rate	m ³ /day	10	15	20	30
Tank size (φ 2,500 x 2,800H)	L (mm)	5,500	6,600	8,150	7,650+3,950
Rated power (380V)	kW	1.20	1.20	1.55	1.55
Tank size (φ 2,050 x 2,200H)	L (mm)	6,650	9,050	7,800+3,850	8,325+8,325
Rated power (380V)	kW	1.55	1.55	1.55	2.30

- Size (mm) : In case of φ 2,500
- Size (mm) : In case of φ 2,050

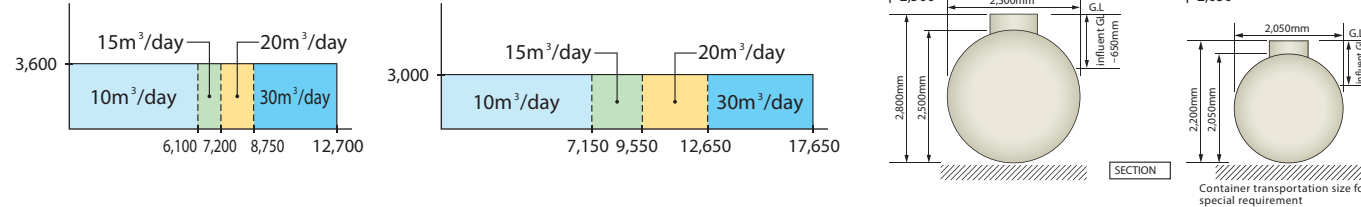

The company reserves the right to change the above specifications without notice. ©2019 Kubota corporation

Flow equalization-type moving bed media filter process

K-HC-R

Flow rate (m³/day)
20.0 ~

- Achieves stable treatment with the flow control function + moving bed carrier filter process
- Adaptable to various building applications by changing the flow control ratio

■ Cross-section perspective

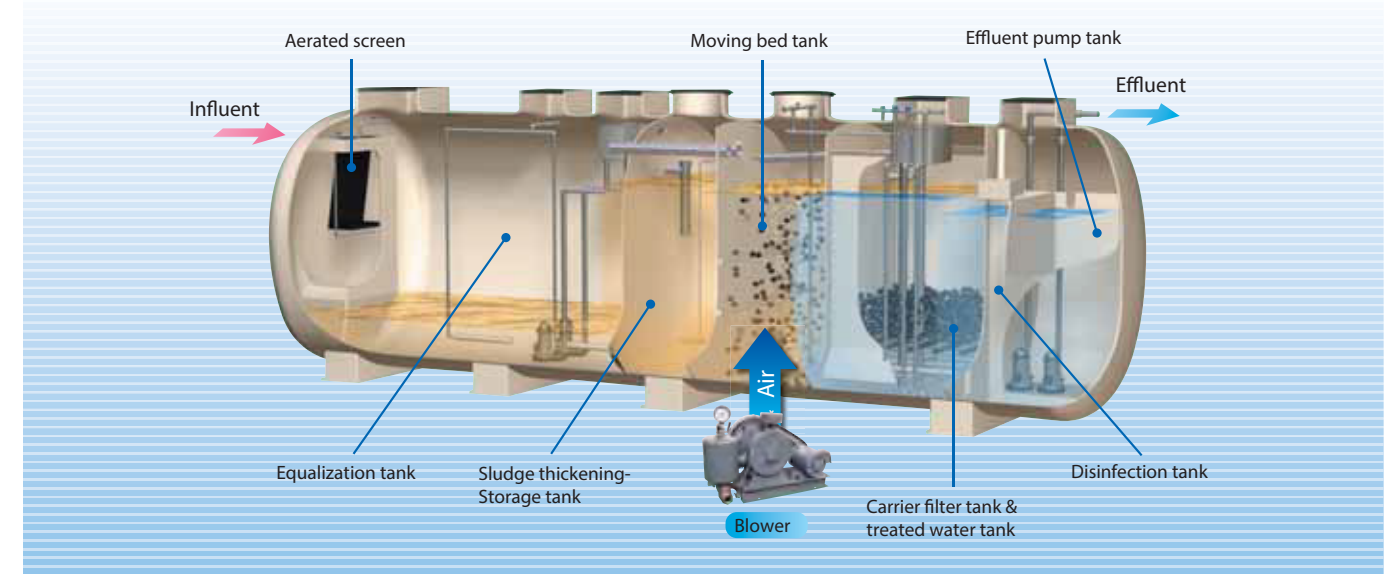

■ Flow sheet

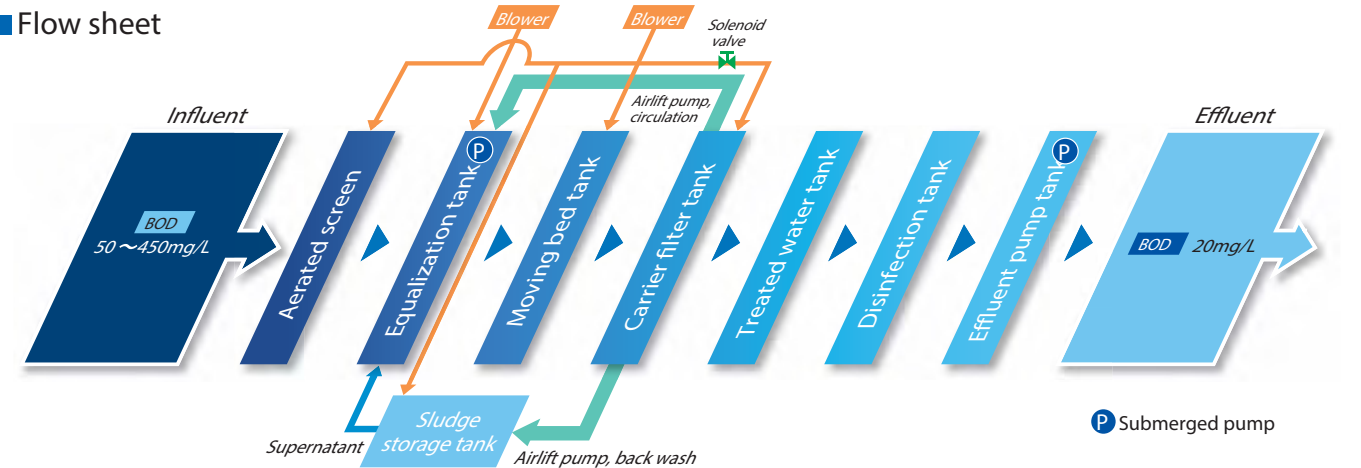

■ Specifications (inf. BOD 200 mg/L, influent 12 hrs/day)

Flow rate	m ³ /day	20	30	70	100
Tank size (φ 2,500 x 2,800H)	L (mm)	6,050	7,450	7,250+8,050	10,000+6,100+5,400
Rated power (380V)	kW	2.55	2.55	3.40	3.50
Tank size (φ 2,050 x 2,200H)	L (mm)	7,950	10,700	4,150+9,650+9,650	9,200+10,650+5,850+7,250
Rated power (380V)	kW	2.55	2.55	4.55	4.55

- Size (mm) : In case of φ 2,500
- Size (mm) : In case of φ 2,050

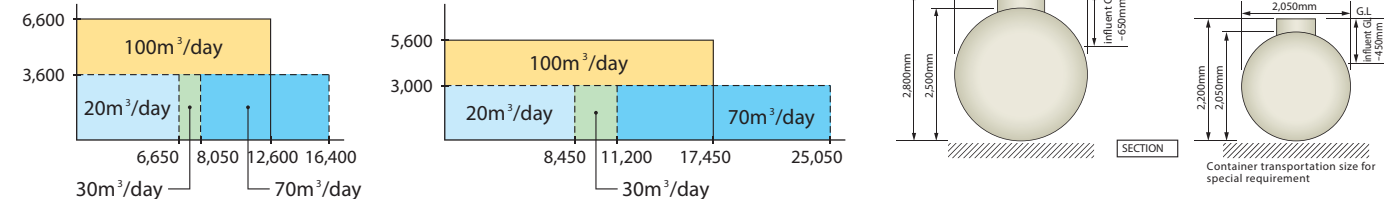

The company reserves the right to change the above specifications without notice. ©2019 Kubota corporation

Membrane bioreactor (MBR) process

KM-SG-NP

Flow rate
(m³/day)
5.1~

N/P removal

Submerged Membrane

Submerged Membrane is patented technology that has been achieved through the combination of Kubota advanced water treatment technology and its unique membrane technology.

- Capable of removing nitrogen and phosphorus by means of membrane separation + recycling-type high concentration activated sludge method + coagulation dephosphorization method

Cross-section perspective

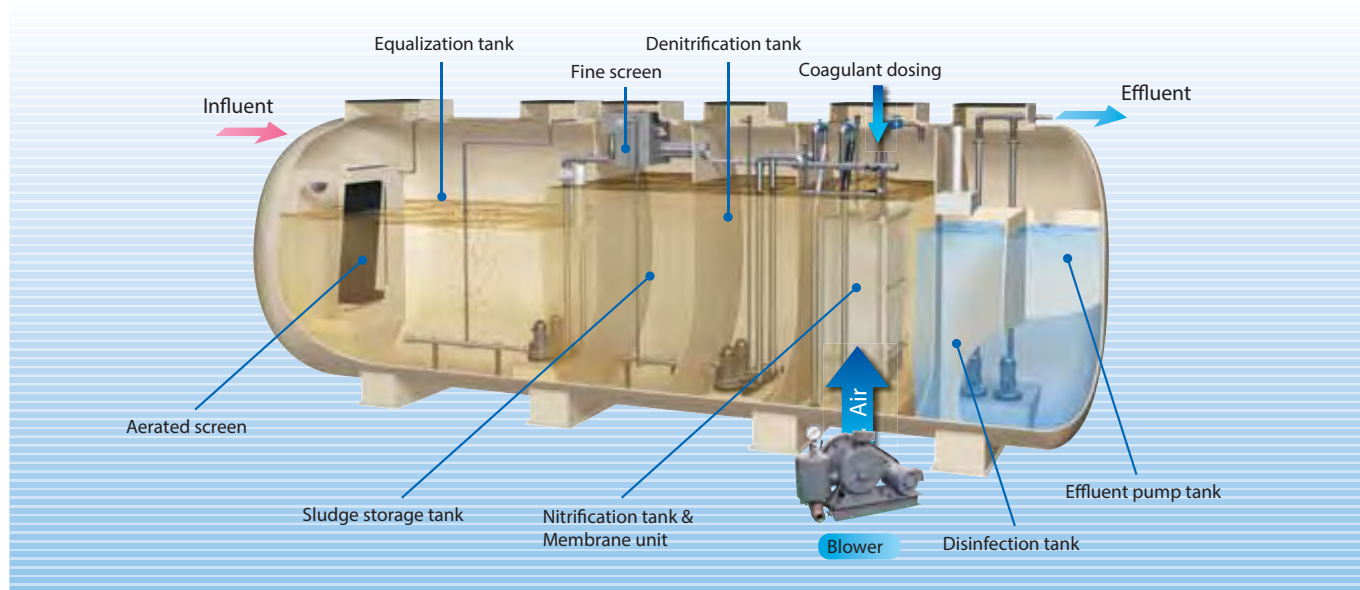

Flow sheet

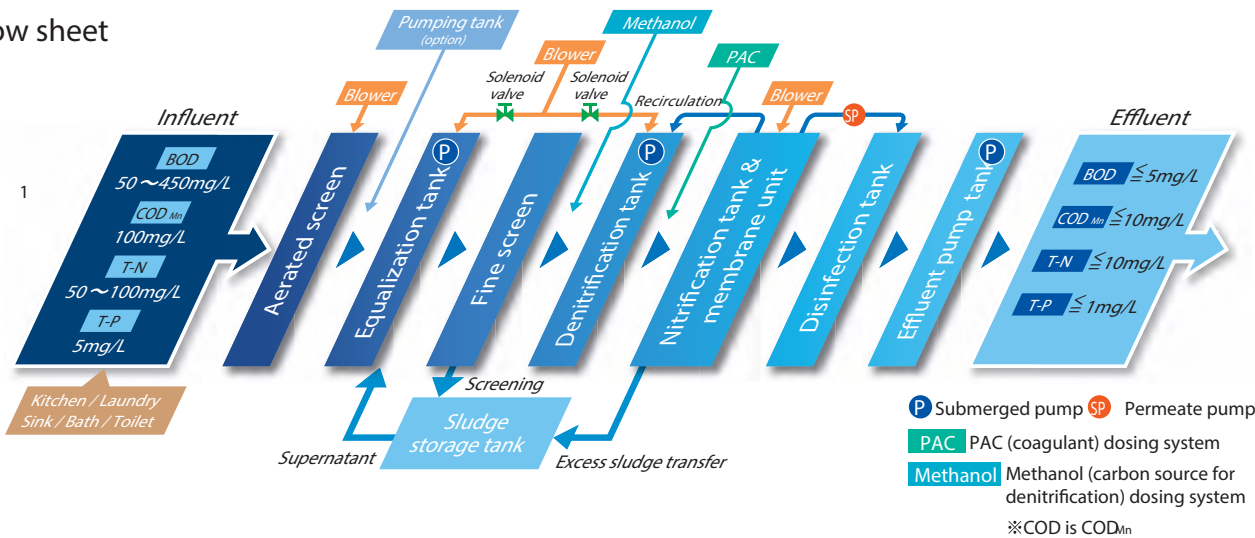

Specifications

(inf. BOD 200 mg/L, influent 12 hrs/day)

Flow rate	m ³ /day	20	40	100	200
Tank size (φ 2,500 x 2,800H)	L (mm)	8,550	6,100+7,950	7,350+8,450 +7,350+8,500	8,250+8,250+6,950+7,700 +8,250+8,300+6,900+7,700
Rated power (200V)	kW	4.0	4.7	8.8	14.9

KUBOTA Submerged Membrane Unit

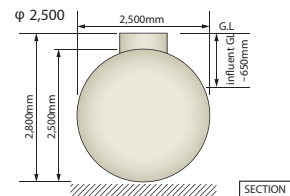
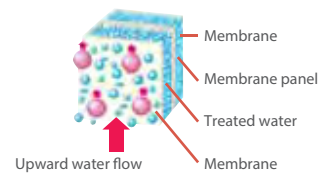

The company reserves the right to change the above specifications without notice. ©2019 Kubota corporation

Hybrid system Reinforced Concrete tank + FRP tank

- Variation of tank configuration for narrow space.
- Former tanks without stuffing are replaced by RC.

Cross-section perspective

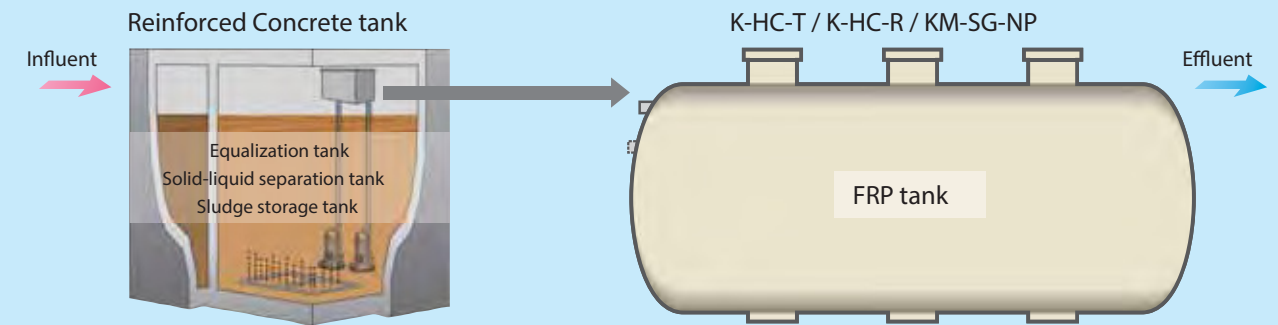

Flow sheet

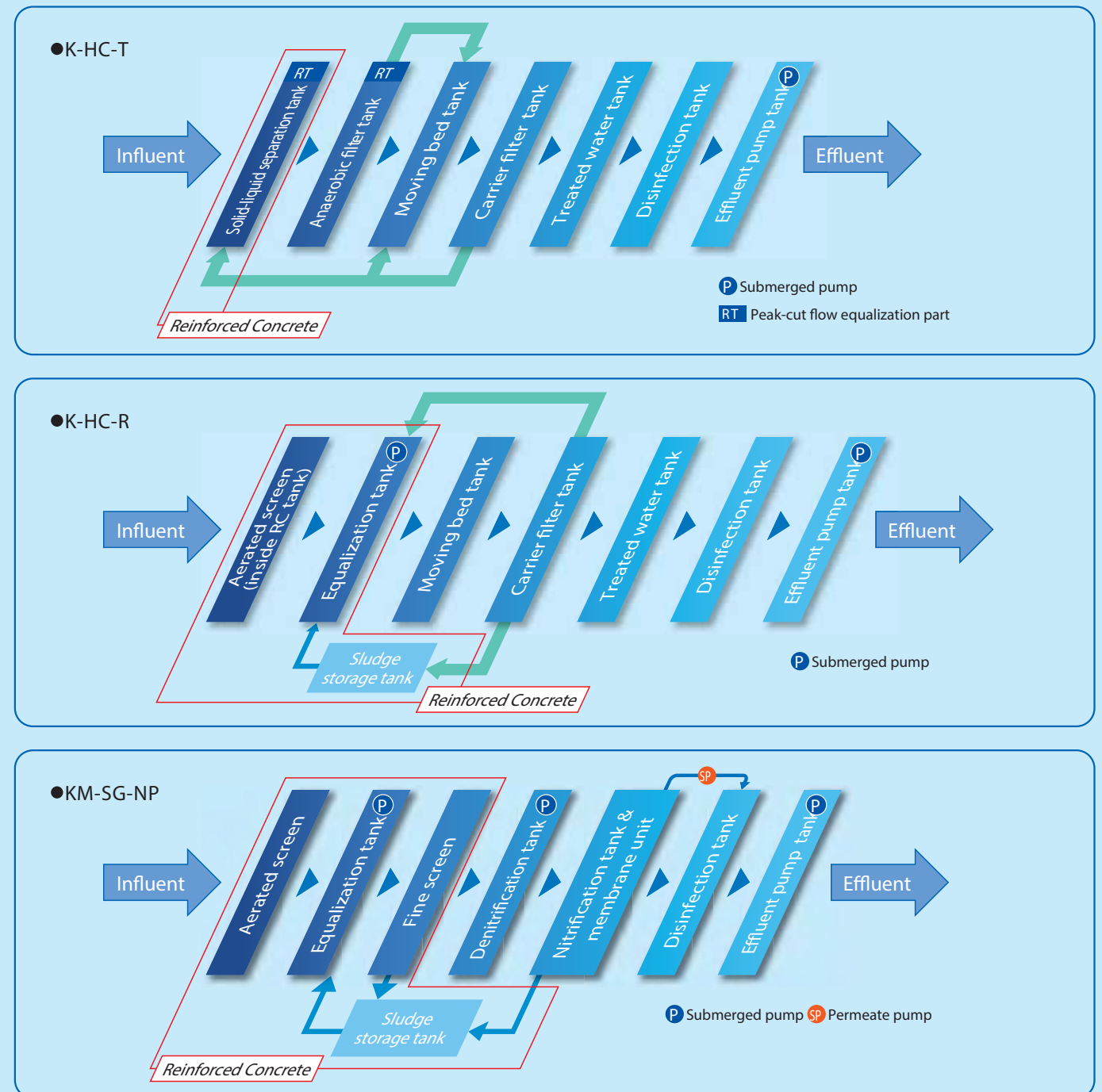

Kubota's Exquisite Effluent Polishing Technology at the Final Stage of Water Treatment

Further Treatment for Johkasou System and the Effluent Improvement for Existing STP

Tertiary Treatment System

Applicable Products | Model HC-AT

Effluent Polishing

Effluent polishing is any process that occurs after secondary treatment. The purpose of the effluent polishing is to further refine the quality of the treated water from the sewage treatment facility as the final process before discharging or reusing the effluent.

Reusable Treated Water

The discharged water from tertiary treatment system can be used for refushing the toilets, sandy dust control, firefighting, irrigations and desert greening. And the surplus water can be returned safely to the aquifers.



Removal of SS, BOD, T-N

Advanced biological and physical treatment processes remove additional suspended solids and carbonaceous biological oxygen demand. Moreover, tertiary treatment allows the extended purification by further nitrification effect.

KUBOTA Advantages

- Kubota tertiary treatment system can set the final effluent to the desired water quality, so that the treated water quality of any existing STP can be improved upward.
- Kubota plans and executes the process design of the tertiary treatment system according to the site requirement by developing the mechanical and electrical designs uniquely on a tailor-made basis.
- Kubota tertiary treatment system purifies the effluent from secondary treatment methodically in the tertiary treatment system, and disinfects the retreated water in order to ensure the safe effluent production.
- Kubota sewage treatment plants represent the most advanced technology available in the world today. These sewage treatment plants satisfy rigorous quality benchmarks and manufacturing standards guaranteeing quality, performance and longevity.

Simple yet Innovative Process, the Most Effective Media are Researched and Developed for the Effluent Polishing

Media flow filter method

Achieving highly efficient treatment with moving bed media

Kubota tertiary treatment tank is the unit with high throughput utilizing the moving bed tank with high performance sponge carrier media and the carrier filter tank with smooth surface cylindrical carrier media. The moving bed media adopts high performance sponge carrier that is highly capable of retaining microorganisms.



Moving bed media
Sponge carrier media
(20 × 20 × 20mm)



Filter media
Smooth-surfaced cylinder
(φ14-16 × 15mm)

- Regarding to use of reclaimed water, please follow your local regulations.
- In addition to the FRP main tank, sand and activated carbon filter can optionally be applied.

HC-AT

Flow rate
2.8m³/day~

- Optional advanced treatment for Johkasou system and the effluent improvement for existing STP.
- The final treatment for effluent polishing to remove remained SS and BOD from the secondary treatment.
- By adopting high-performance carrier media, compactness has been achieved and the workability has been greatly improved.
- According to the local regulations, the level of refinement can be set by your request.

Cross-section perspective

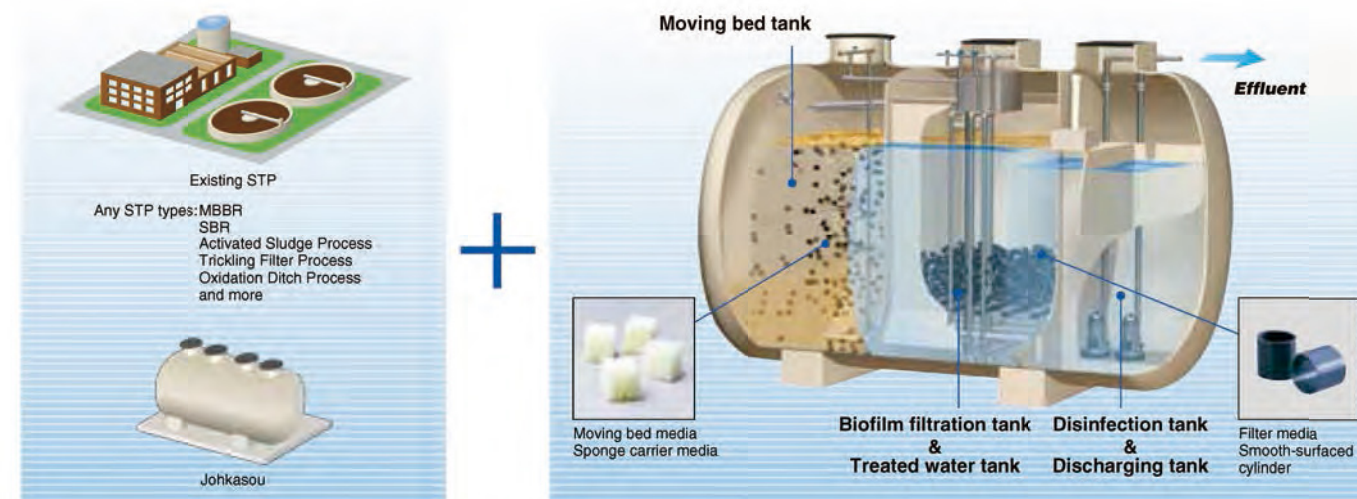

Flow sheet

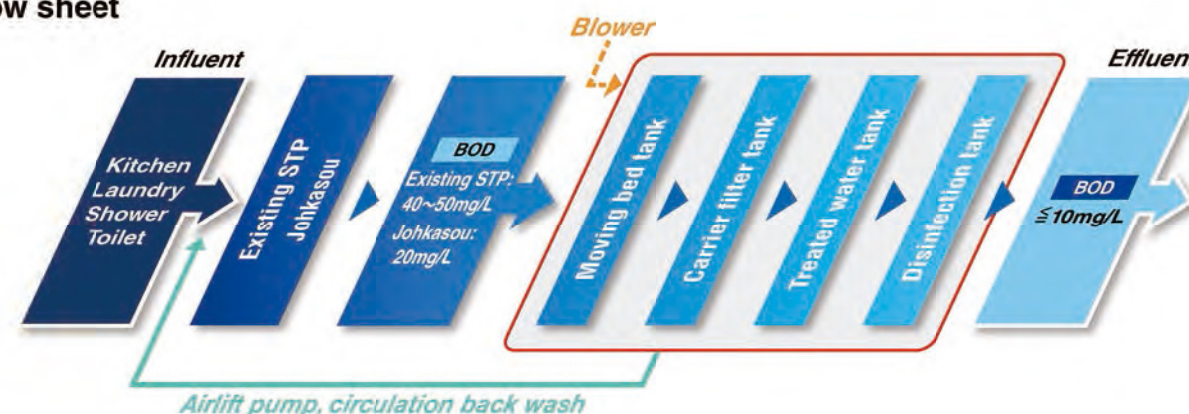

Section view

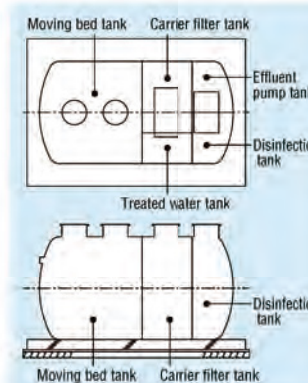

Moving Bed Tank

1. Moving bed tank is an aerobic treatment and the tank is filled with effluent from the secondary treatment and carrier media that convect continuously by diffuser.
2. Biofilms are formed on the surface of the carrier media, and the remaining BOD from the secondary treatment in the pre-process unit becomes oxidized.
3. The tank applies high performance sponge media that is excellent in durability and, as compared with the ordinary PP media, has larger surface area to hold more number of microorganisms in order to make the wastewater treatment ability more effectively.

Carrier Filter Tank

4. The processed water in the moving bed tank is transferred together with the peeled sludge from the opening near the water surface to the following carrier filter tank.
5. Carrier filter tank is filled with carrier media made of tubular plastic, and fine particles as SS adhere to the inside and the surface of the media while the processing water slowly passes through, and by removing these SS, clean and clear treated water is produced.
6. Particle matters for 1 day accumulation inside of the filter bed get automatic air backwashing in the midnight when there is no inflow.
7. The cleaned media resume the filtering process.
8. The SS separated from the carrier media by backwash counterflow by the airlift, and is transported to the primary treatment of Johkasou or existing STP.
9. When the inflow load is high, it is possible to prevent clogging of the filter bed by increasing the number of times of backwashing.

Treated Water Tank, Disinfection Tank and Effluent Pump Tank

10. After the carrier filter tank, the water is stored in the treated water tank, processed to be safe in the disinfection tank, and discharged from the effluent pump tank as reclaimed water.

Kubota's FRP Johkasou in use around the world

Application for Johkasou

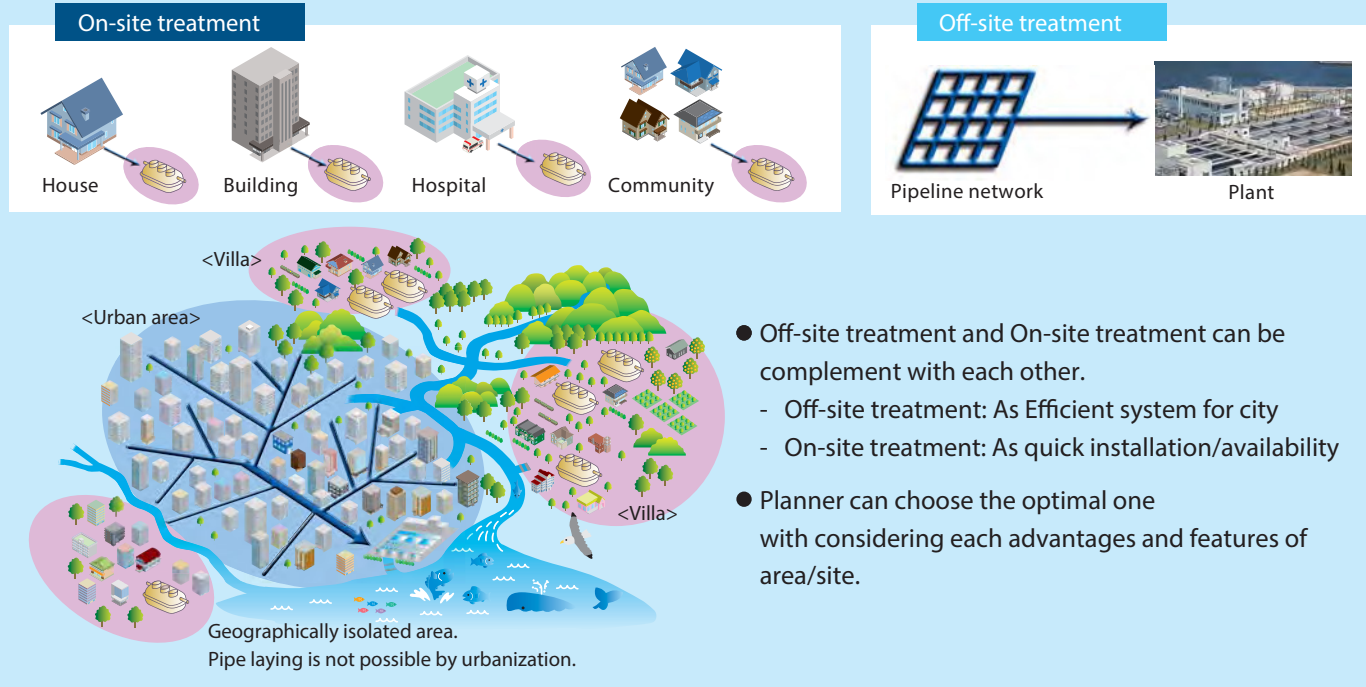

- Off-site treatment and On-site treatment can be complement with each other.
 - Off-site treatment: As Efficient system for city
 - On-site treatment: As quick installation/availability
- Planner can choose the optimal one with considering each advantages and features of area/site.

Feature of Kubota Johkasou

Hydraulics

- Small & Large size Pipe hydraulics and its network technology
- Large size pump hydraulics
- Large size valve hydraulics

$$\frac{\partial}{\partial t} \left(\frac{\partial v}{\partial x} - \frac{\partial u}{\partial y} \right) + u \frac{\partial}{\partial x} \left(\frac{\partial v}{\partial x} - \frac{\partial u}{\partial y} \right) + v \frac{\partial}{\partial y} \left(\frac{\partial v}{\partial x} - \frac{\partial u}{\partial y} \right) = \frac{\mu}{\rho} \left(\frac{\partial^2}{\partial x^2} \frac{\partial v}{\partial x} - \frac{\partial u}{\partial y} \right) + \frac{\partial^2}{\partial y^2} \left(\frac{\partial v}{\partial x} - \frac{\partial u}{\partial y} \right)$$

Bio-engineering

- Large scale STP
- MBR process (pioneer)
- Advanced treatment
- Human excreta treatment

Production Engineering

- Tractor,
- Combine harvester
- Backhoe
- Engine
- Pipes
- Pumps
- Valves
- Membrane etc.

Made in Japan

Kubota

- Shiga Plant
- FRP Subcontract factory fully instructed by Shiga Plant

Installation work

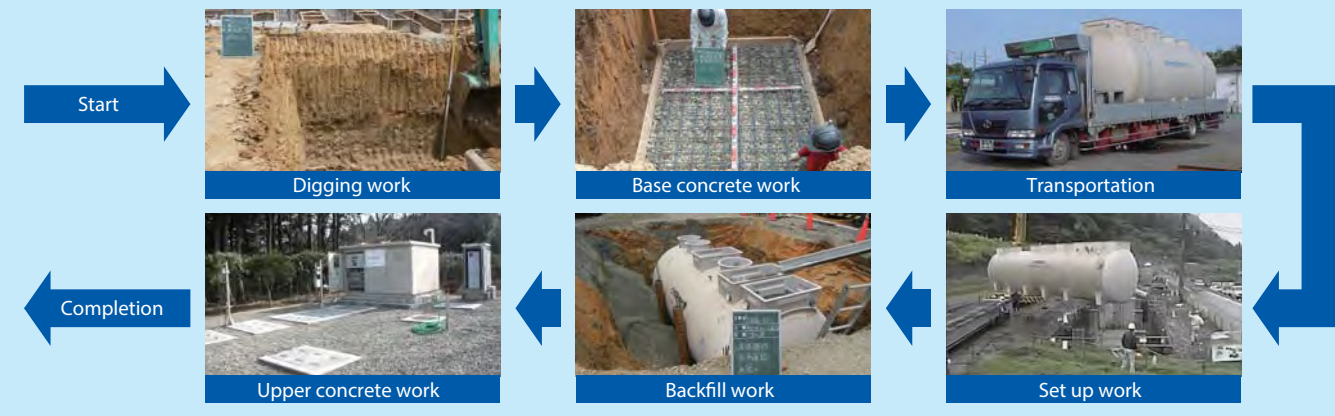

Overseas transportation



Container type

Saudi Arabia: Water recycling



Flow rate 530 m³/day

Vietnam: for Factory sewage



Flow rate 80 m³/day

Vietnam: for Factory sewage



Flow rate 12 m³/day

Vietnam: for Hospital sewage



Flow rate 50 m³/day

Vietnam: for Individual residence sewage



Flow rate 1.0 m³/day



Water



Food



Kubota Continues Support for Global “Food, Water and Environment” Now and in the Future

Kubota’s 125 years of history has been one of facing up to social challenges. Our commitments—Creating a better social foundation and Supporting people’s day-to-day lives—have never changed from our establishment until today, 125 years later. “For Earth, For Life”

Kubota will continue making every effort to support people’s smiles and rich day-to-day lives in the future by contributing globally to addressing common issues we all face: “Food,” “Water,” and “Environment.”

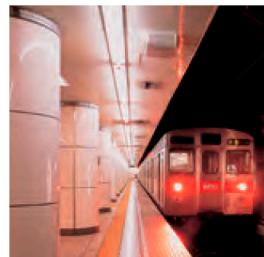
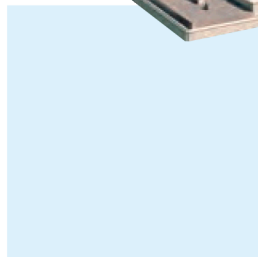

Environment

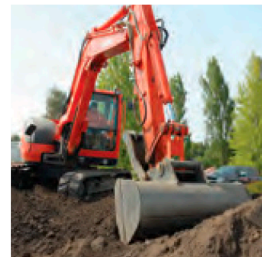

Phone

UAE +971 50 926 9993

Somaliland +252 63333 9936



H2O Falcons for Water Treatment Trade
Abu Dhabi, United Arab Emirates

URL www.h2ofalcons.com

E-mail info@h2ofalcons.com